

FINS ARE THE BEST WAY TO STABILIZE A BODY IN THE WATER.

Billions of fish can't be wrong!



COMPACT ELECTRIC STABILIZERS
FOR YACHTS 12 M AND UP!



TECHNICAL LEADERSHIP

Waveless STAB is the new generation of electric fin stabilizers created by CMC Marine, the undisputed leaders in electrically-actuated fin stabilization, chosen by the world's leading yacht builders.

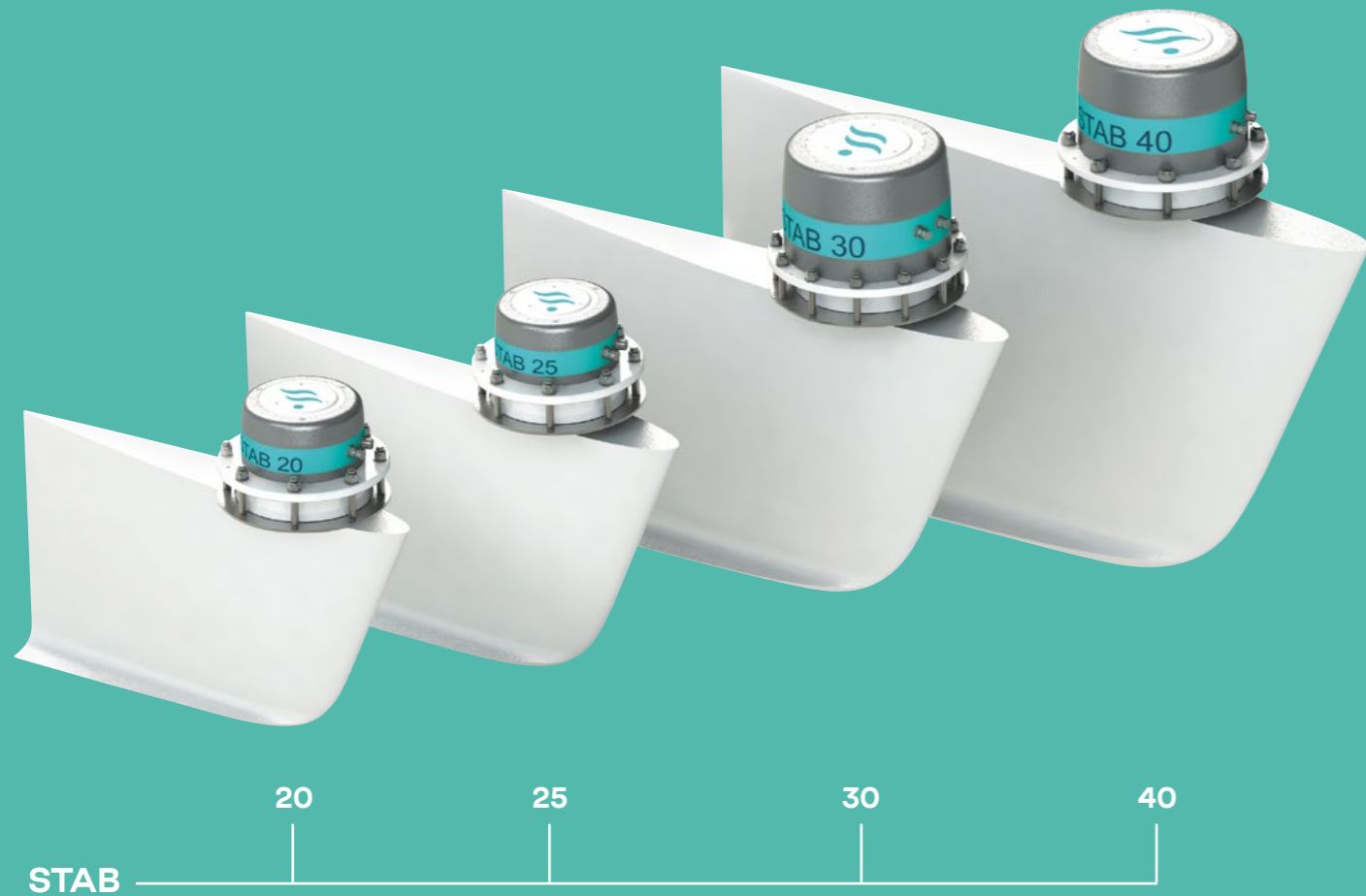

Picture courtesy of Arcadia Yachts photo archive

The World's leading yacht builders choose ours systems for their creations.



UNCOMPROMISED COMFORT

Best-in-class roll reduction both Underway and At Anchor.

Immediate ON/OFF: ready to work when you need it, no waiting for system start-up.

Same unique, patented software used on much larger superyachts up to 75 m.



Picture courtesy of CL Yachts photo archive

AT ANCHOR

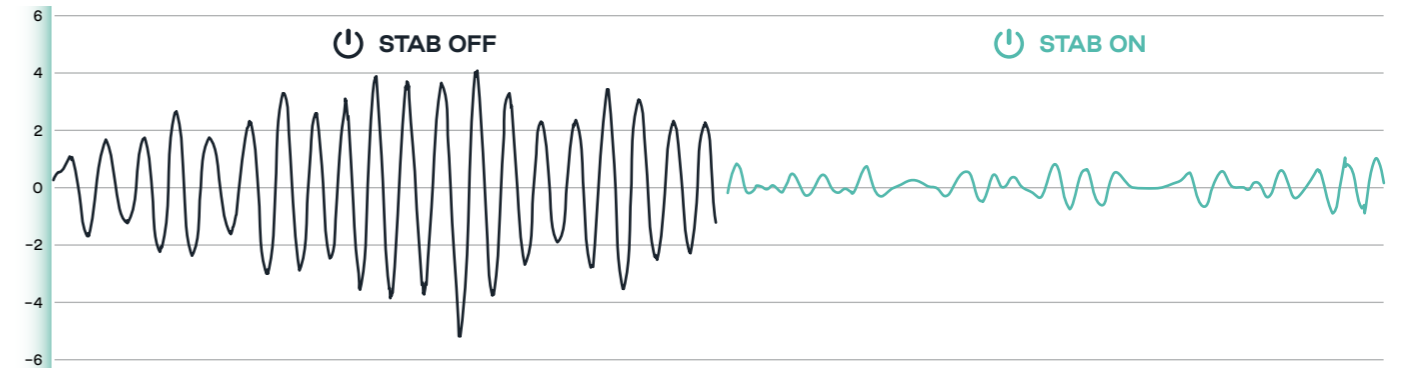

ROLL REDUCTION

Average: -76%
Peak: -86%

POWER ABSORPTION

Average: 0,2 kW
Peak: 1,5 kW

UNDERWAY

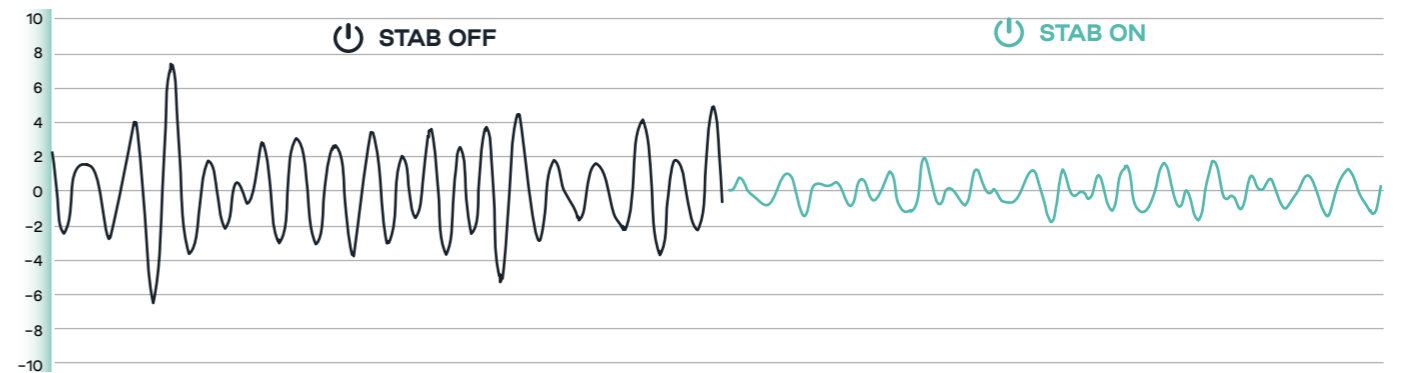

ROLL REDUCTION

Average: -71%
Peak: -78%

POWER ABSORPTION

Average: 0,1 kW
Peak: 0,5 kW

Sea trial data: Displacement 65 tons, Waveless STAB30, wave height 2 m.

INNOVATION BEYOND IMAGINATION

Industry-leading electrical actuation and Superior mechanical design make Waveless STAB the simplest and best performing solution to stabilize your yacht:

- small footprint
- great performance
- unrivalled reliability

Waveless STAB is available in both 2-fin and 4-fin configuration to provide the perfect stabilizations solution to every project.

FIN

Super-light, foam-filled.

GRP lamination has natural shock-absorbing properties and makes our fins durable and highly resistant to wear and tear.

HULL BUSHING

Available for installation on GRP, Wood, Steel, Aluminium hulls.

BRAKE

Automatically activated to lock the fins when required for maximum safety.

MOTOR

AC Torque, Brushless type: this is the heart of STAB's technology and performance.

STAB motors rotate the fins at up to 90° degrees per second.

SHAFTLESS DESIGN

Makes handling easy and maintenance inexpensive.

EPICYCLOIDAL GEARBOX

Low-noise, high efficiency and zero maintenance.

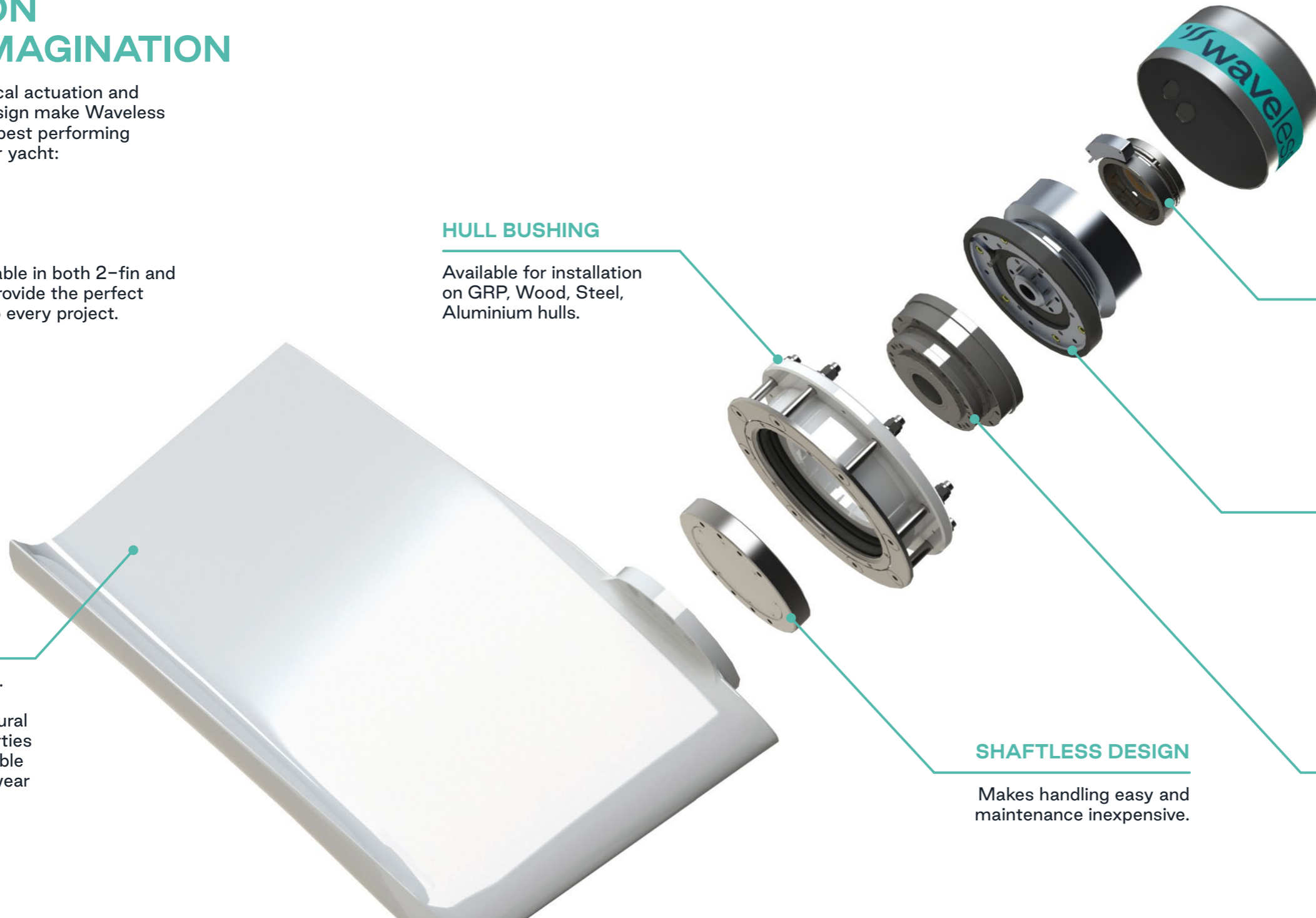

UNIQUE FEATURES

Waveless products are designed by industry experts who dedicated on optimising the functionality and performance making it perfect in nearly all conditions and for all users, from the professional Captain to the enthusiast boat Owner.

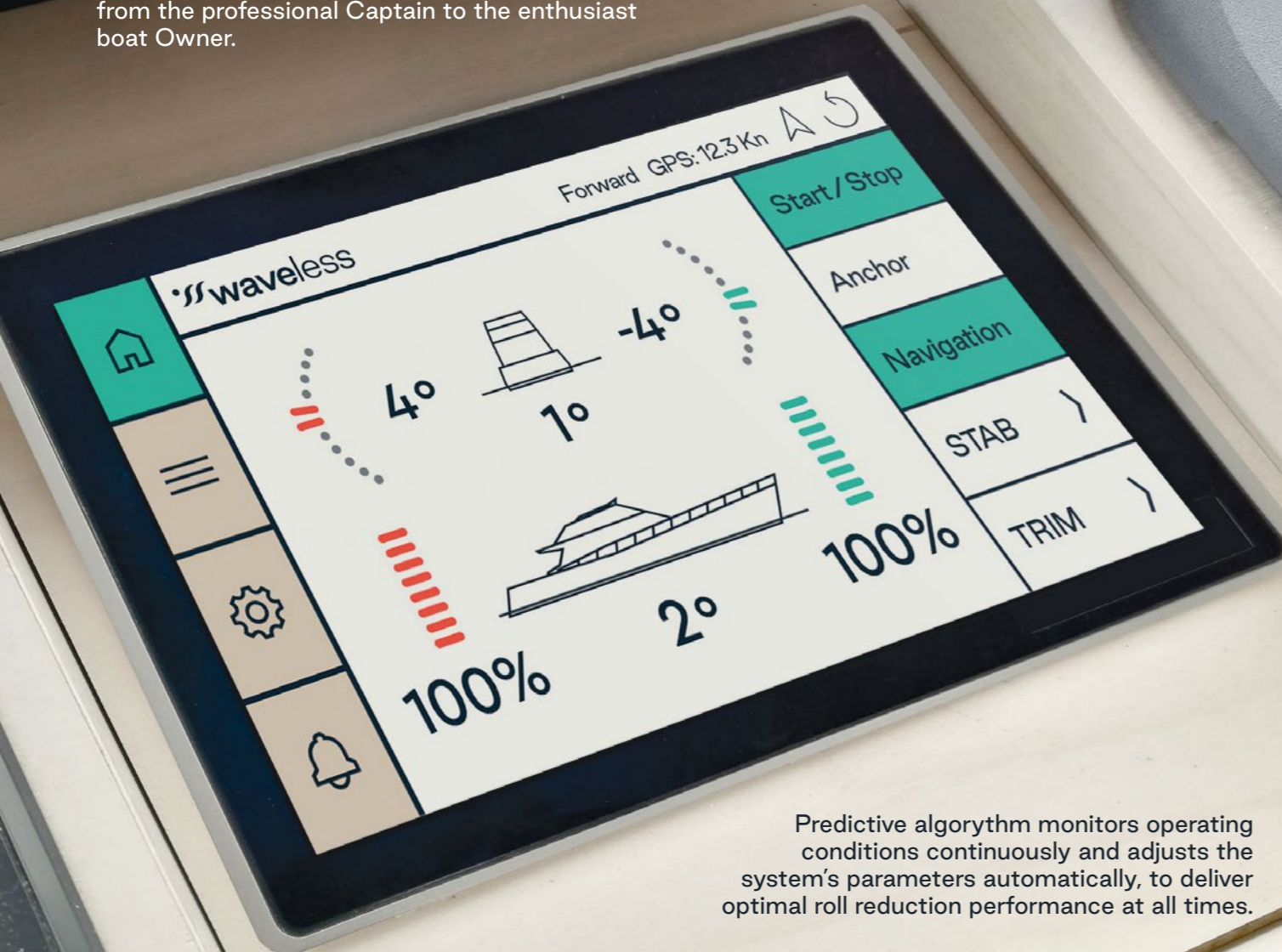

Predictive algorithm monitors operating conditions continuously and adjusts the system's parameters automatically, to deliver optimal roll reduction performance at all times.

FLIP



Rotate fins while At Anchor to prevent anchor walk.

MSS



Keep the anchor mode active at low maneuvering speeds.

NIGHT MODE



Reduce energy consumption to extend batteries duration.

DOCK MODE



Limits max fin angle.

REMOTE ASSISTANCE



Your Waveless service team can be with you, wherever you need us.

*Option available for STAB20 and STAB25.

OPTIMIZED FOR HIGH-SPEED HULLS

The fins' zero position is adjusted during navigation to align to the hydrodynamic flow.

This unique feature ensures minimal impact on hull resistance and makes a Waveless STAB the ideal solution for high speed hulls.

LOW SPEED

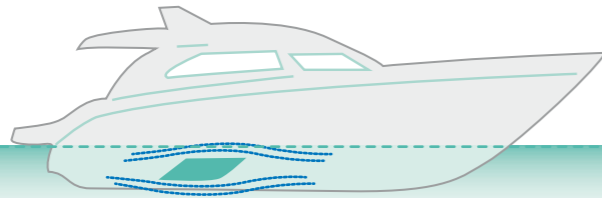

OTHERS

waveless

HIGH SPEED

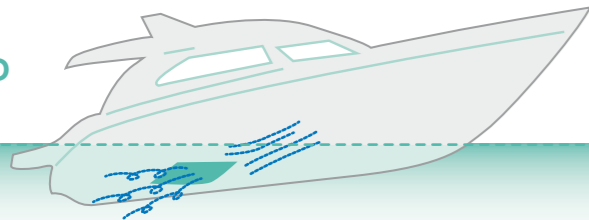

HIGH DRAG

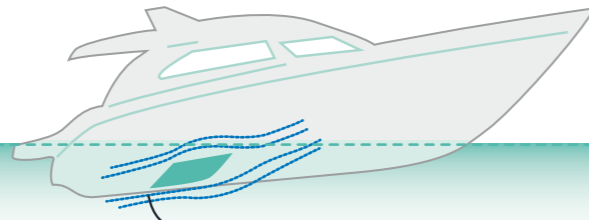

LOW DRAG
(fin rotated to follow the hydrodynamic flow)



INSTALLATION MADE EASY

Electrical actuation makes Waveless STAB very simple to install, with a smaller footprint and much less hardware than needed by an hydraulically-actuated fin stabilizer system.

A lot more comfort with a lot less complications:

No hydraulic lines, no oil reservoir, no PTO pump and power pack, no cooling system, no wear-and-tear mechanical components.

Waveless STAB is the right choice for your yacht.



EPU box

Electronic Power Unit
Contains the servo drive(s) which
feed current to the motors

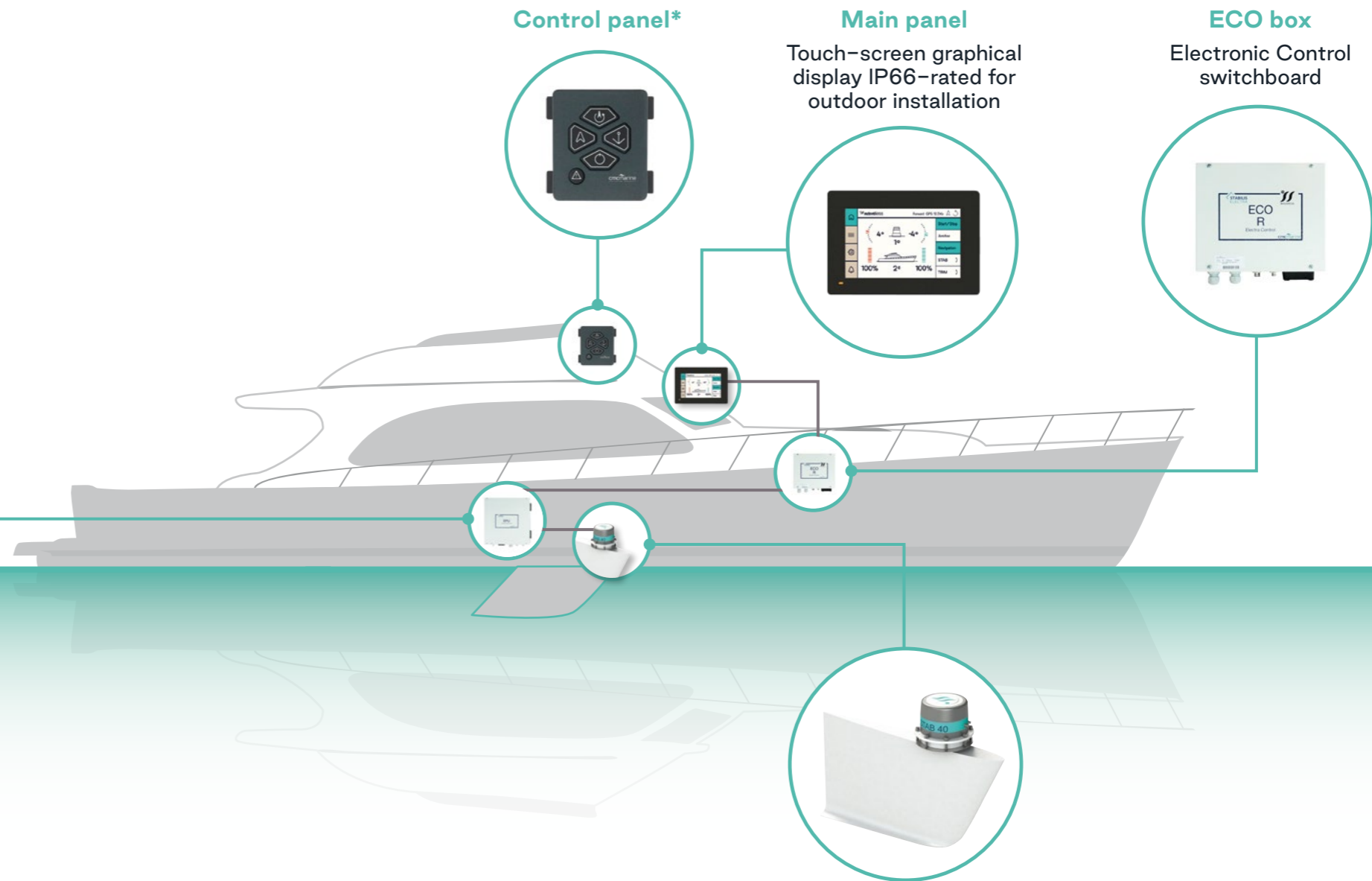

Control panel*



Main panel

Touch-screen graphical
display IP66-rated for
outdoor installation



ECO box

Electronic Control
switchboard



STAB actuator

Available in 2-fin and 4-fin to
meet your vessel characteristics
and roll-reduction requirements

*Optional

THE SMART CHOICE



TOP QUALITY

Best-in-class roll reduction both Underway and At Anchor, with softer (lower acceleration) yacht motion for unequalled comfort.



ULTRA COMPACT

The smallest unit has onboard dimensions of 38 centimeters in diameter and 22 centimeters in height.



LOWER MAINTENANCE

Zero maintenance required on electrical motor and gearbox. Remote assistance options for online, real-time diagnostics.



ECO FRIENDLY

No risk of oil spills and damaging pollution. More than 90% of the manufacturing materials are from recyclable materials.



LOW NOISE

Silent! Negligible noise and vibration, often installed under Owner's or VIP's beds.



LOW POWER CONSUMPTION

High efficiency (>85%) means lower power demand on generators and reduced energy consumption.



FAST RESPONSE

Immediate ON/OFF mode.

WARRANTY

So reliable that we are prepared to back our claims with our industry leading warranty:



STANDARD WARRANTY:

2 YEARS
and no limit on the
running hours.





FINS ARE THE NATURAL WAY TO ADAPT TO SEA CONDITIONS.

Billions of fish can't be wrong!

**COMPACT ELECTRIC STABILIZERS
FOR YACHTS 12 M AND UP!**



STAB

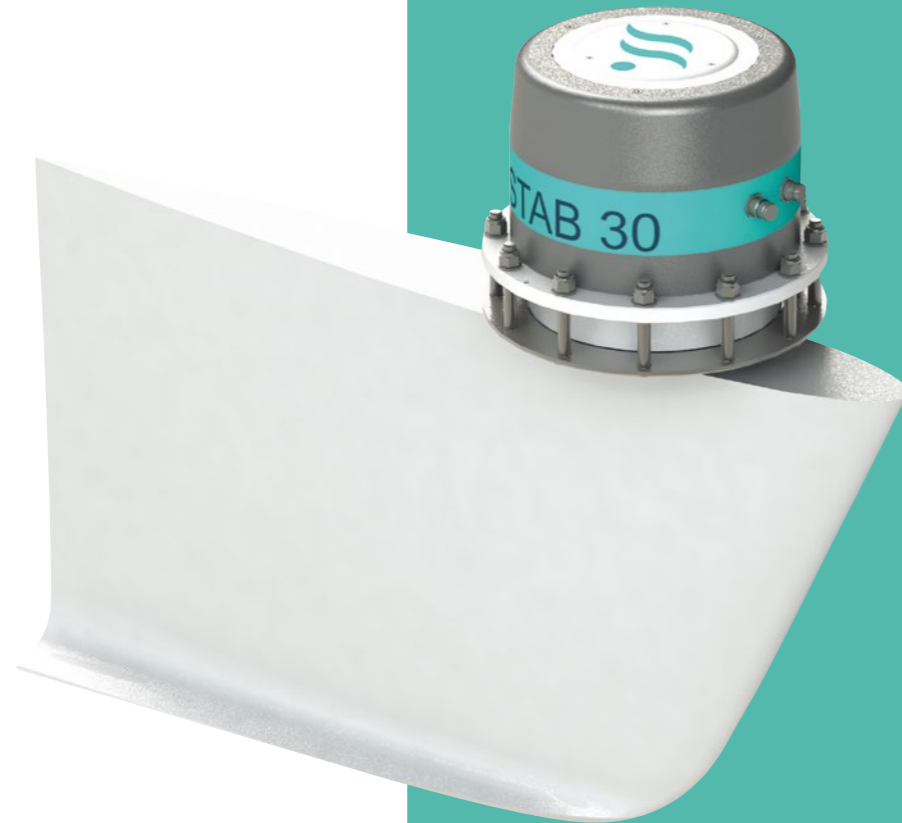

TECHNICAL DATA

STAB	20	25	30	40
Power supply	200-240 V AC 1ph 50/60 Hz optional: 24 V DC	200-240 V AC 1ph 50/60 Hz optional: 24 V DC	200-240 V AC 1/3ph 50/60 Hz optional: 24 V DC	200-240 V AC 1/3ph 50/60 Hz 380-480 V AC 3ph 50/60 Hz
Power absorption - Underway	0-1 kW (avg 0,1 kW)	0-1,5 kW (avg 0,2 kW)	0-2,5 kW (avg 0,35 kW)	0-4 kW (avg 0,55 kW)
Power absorption - At Anchor	0-2 kW (avg 0,25 kW)	0-3 kW (avg 0,5 kW)	0-4,5 kW (avg 0,75 kW)	0-7,5 kW (avg 1,25 kW)
Fin size	0,50 sqm	0,65 sqm 0,80 sqm	0,90 sqm 1,10 sqm	1,25 sqm 1,50 sqm
Weight*	57 kg	57 kg	105 kg	108 kg

* Actuator only

QUICK INSTALLATION

Waveless STAB is designed to be installed easily in just 5 QUICK STEPS.*

01

Prepare the hull with the required thickness for the installation and cut the hole for the STAB actuator (don't forget the holes for the bolts too!).

02

Insert the STAB actuator in the hole (no matter the position) from inside the hull and seal it with chockfast.

03

Place the counter flange on the outside and secure the STAB actuator to the hull using the bolts.

04

Place the fin flange on flange with the STAB actuator and fasten the bolts.

05

Plug in the power cable and encoder cable connectors.

GO!

Enjoy your boat!

*Procedure for GRP hulls, contact us for details of installation on wood, steel aluminium.

01

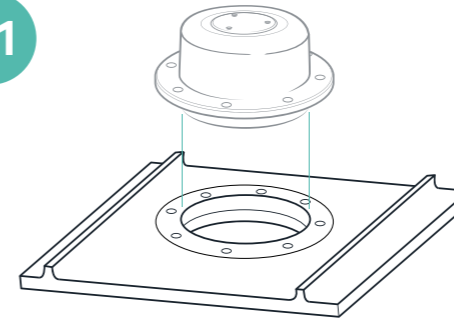

02

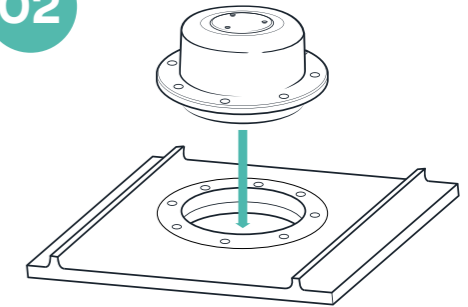

03

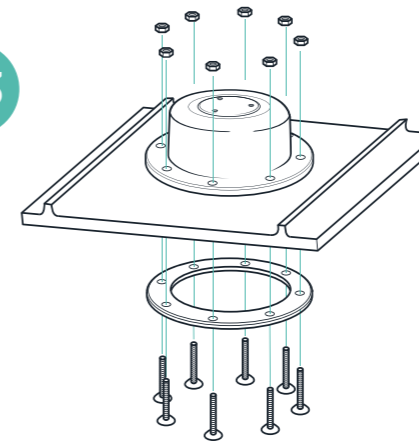

04

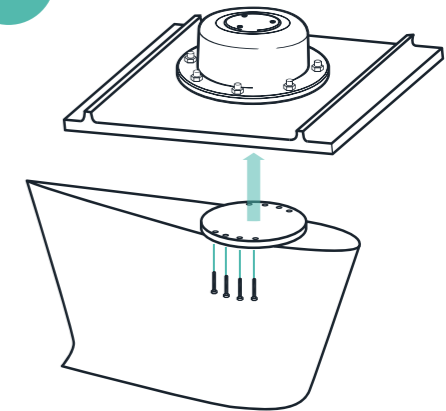

05

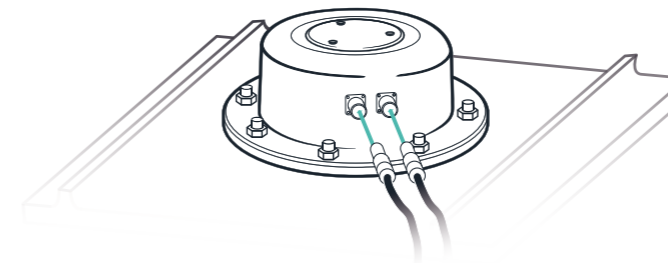

A GLOBAL SERVICE NETWORK

Get technical and sales assistance in your navigation area from our service centers and resellers, all around the world.

Furthermore, all Waveless systems can be equipped with optional remote assistance module.

Contact: info@wavelessmarine.com

> www.wavelessmarine.com/service

> www.cmcmarine.com/service

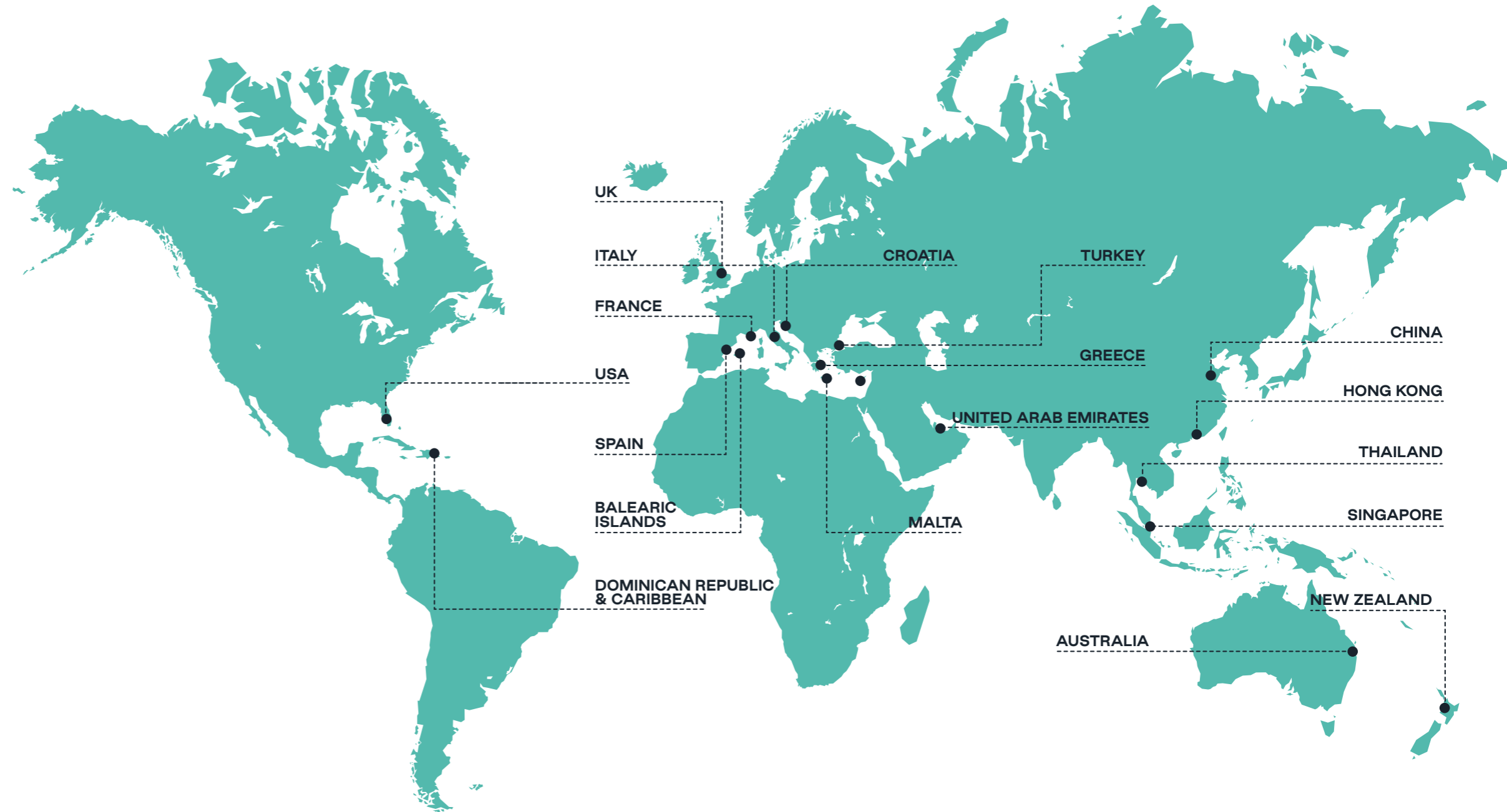

FINS ARE A PROVEN TECHNOLOGY.

Billions of fish can't be wrong!

COMPACT ELECTRIC STABILIZERS
FOR YACHTS 12 M AND UP!

